

# INDUSTRIAL HOSE REELS IN PAINTED STEEL MOTORIZED 115V ELECTRIC SERIES Mod. FE-700

## For air-water and diesel 20 bar

Equipped with:

- Anodized aluminium swivelling joint
- Viton® seals
- **Electric 115V AC motor** 451W power

Article	Model	Internal reel width	Inlet-Outlet
076-7152-900	FE-701	330 mm	F2"- F2" BSP
076-7252-900	FE-702	440 mm	F2"- F2" BSP
076-7352-900	FE-703	550 mm	F2"- F2" BSP



FE-701

## For oil and lubricants 250 bar

Equipped with:

- Anodized aluminium swivelling joint
- NBR seals
- **Electric 115V AC motor** 451W power

Article	Model	Internal reel width	Inlet-Outlet
076-7156-900	FE-701	330 mm	F2"- F2" BSP
076-7256-900	FE-702	440 mm	F2"- F2" BSP
076-7356-900	FE-703	550 mm	F2"- F2" BSP



FE-702

## Hose reel capacity

Ø Hose	Ø external Hose	Mod.FE-701	Mod.FE-702	Mod.FE-703
1.1/4"	43 mm	35 m	45 m	60 m
1.1/2"	50 mm	20 m	30 m	50 m
2"	63 mm	15 m	25 m	30 m

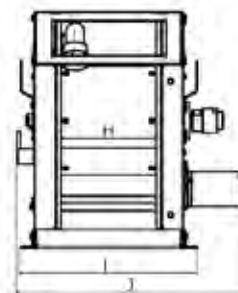
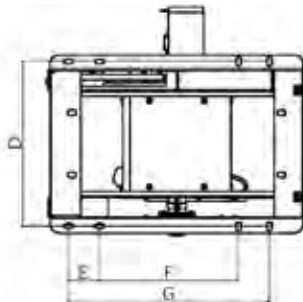
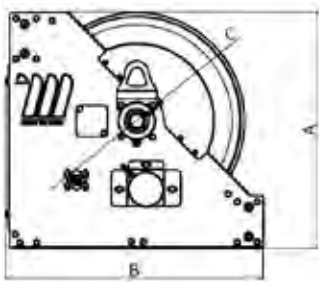

FE-703

## Overall dimensions

Model	A	B	C	D	E	F	G	H	I	J	Weight	Packaging
FE-701	760	833	700	531	100	450	650	330	574	734	122 kg	800X1200X950 mm
FE-702	760	833	700	641	100	450	650	440	684	844	140 kg	1000X1200X950 mm
FE-703	760	833	700	751	100	450	650	550	794	954	155 kg	1000X1200X950 mm

The industrial hose reels with **electric motor 115V** are designed for applications that require robust equipment, also on trucks. They are suitable for flexible hoses with big diameters for the distribution of compressed air, oil and similar, diesel.

The unwinding of the hose is manual while the rolling process is through the electric motor (115 AC). It has to be connected to the 115V AC electric network.