

Art. 011-0920-P60

Air-operated industrial pump for grease R=20:1
Mod. 920P flanged double-effect
 For frame lifter press (shank length 600 mm)
 Polyurethane seals
 For high viscosity grease and oil

Art. 011-0950-P50

Air-operated industrial pump for grease R=50:1
Mod. 950P flanged double-effect
 For frame lifter press (shank length 500 mm)
 Polyurethane seals
 For high viscosity grease and oil

Art. 011-1240-P60

Air-operated industrial pump for grease R=40:1
Mod. 1240P flanged double-effect
 For frame lifter press (shank length 600 mm)
 Polyurethane seals
 For high viscosity grease and oil

Art. 011-1270-P50

Air-operated industrial pump for grease R=70:1
Mod. 1270P flanged double-effect
 For frame lifter press (shank length 500 mm)
 Polyurethane seals
 For high viscosity grease and oil

Art. 011-1575-P60

Air-operated industrial pump for grease R=75:1
Mod. 1575P flanged double-effect
 For frame lifter press (shank length 600 mm)
 Polyurethane seals
 For high viscosity grease and oil

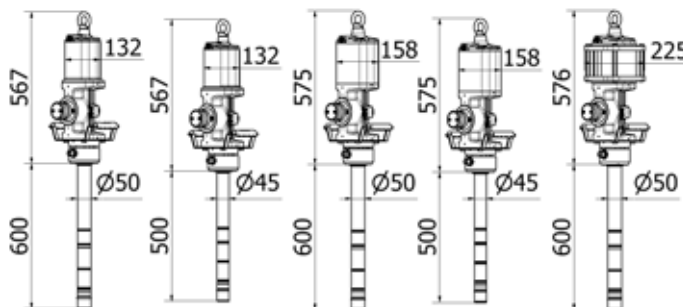

Art. No.	Weight (Kg)	Volume (m³)	Quantity (N°)
011-0920-P60	20,800	0,110	1
011-0950-P50	21,600	0,110	1
011-1240-P60	22,100	0,110	1
011-1270-P50	22,800	0,110	1
011-1575-P60	28,000	0,110	1

Technical data		011-0920-P60	011-0950-P50	011-1240-P60	011-1270-P50	011-1575-P60
Compression ratio		20:1	50:1	40:1	70:1	75:1
Max supply pressure	bar	8	8	8	8	8
Air consumption 8 bar	m³/min	1,75	1,75	2,90	2,90	4,30
Air inlet connection	BSP	F 1/2"G	F 1/2"G	F 1/2"G	F 1/2"G	F 1/2"G
Grease outlet connection	BSP	F 1/2"G	F 1/2"G	F 1/2"G	F 1/2"G	F 1/2"G
Grease delivery capacity 8 bar	g/min	12000	6800	10000	6000	8000
Noise	dB	80	80	80	80	80
Shank diameter	mm	50	45	50	45	50
Shank length	mm	600	500	600	500	600
For drums with capacity of	kg	180-220	180-220	180-220	180-220	180-220

Suitable for high pressure transfer of high viscosity grease (maximum NLGI 3) over short and long distances. The double effect grants the supply of a constant and continuous flow. They are suitable for central distribution plants with multiple distribution points.